



## Choosing a Model

---

*It is essential to choose a suitable trainer as your first model. You may like the look of that quarter scale Sea Fury kit taking pride of place in the model shop window, but it is not a practical proposition for a first model, or even a second!*

*The typical power trainer will be a high wing arrangement, with sufficient stability to allow the model to fly 'hands-off' while the student thinks about what to do, and to be able to fly slowly enough to allow the student time to think. A larger model (up to about 6 foot wingspan) has the advantage of being easier to see, and can also have an advantage in being smoother in flight, but requires more resources when building and repairing. Most trainers are of simple lines and construction both for ease of initial construction and to make any repairs simpler, but there is no reason why it should not have a scale-like appearance, subject to the constraints already described.*

*Power models should have at least 3 functions: throttle, rudder and elevator, although provided the student is using the services of an instructor, there is no reason why a trainer should not have aileron control as well. The undercarriage arrangement will usually be tricycle, rather than tail-dragger, as this makes ground handling easier. However, there is no reason why a tail dragger should not be used if preferred. The engine should be easily accessible and preferably mounted upright or sideways. Inverted engines are useful when trying to hide them in a scale cowl but this can sometimes make starting more difficult than necessary.*

### *Should I build from scratch or buy a kit?*

*There are many options for acquiring your first model, all with their own advantages and disadvantages; you can -*

- 1. build from plans*
- 2. buy a semi-kit*
- 3. buy a complete kit*
- 4. buy an ARTF - Almost Ready To Fly kit*
- 5. buy a used model*

*There are hundreds of plans available, for practically any sort of model. You can buy them from specialist publishers such as Nexus, who have a catalogue of designs from many different designers; from individual designers who specialise in one type of model, such as scale; and many modelling magazines publish free plans, complete with a guide to construction. Many people like this start-to-finish approach but it does require a higher*

*degree of constructional skill. Beginners are also less likely to have wood or accessories already to hand and will have to buy everything needed: these items may be specified on the plan but if not then you will have to choose and source all the necessary parts yourself.*

▶ *One step up from a plan is a semi-kit; that is a plan plus some of the parts required to build it. Usually it includes moulded and plywood components, but you are left to buy the remainder of the wood and parts required to complete the model. The advantages are that you are then free to use the materials and hardware, hinges, engine mounts and so on, of your choice. For experienced modellers this can be a cost saving as they have probably built up a stock of components from other projects, as well as leaving them free to use their judgement on their preferred type or brand of equipment; the beginner will of course have to buy everything new.*

▶ *The Kit option provides you with practically everything you need to complete a model. Often the only thing not provided is the covering material, and sometimes even that is included. The advantages for a beginner are that there is little else to buy, and the kit manufacturer will have ensured that the hardware provided is suitable for the model. The amount of building required can vary immensely; model designs range from traditional balsa based model construction which can require many hours to complete, to models with foam cored wings and glass-fibre moulded fuselages which can be completed in a few evenings work. Each style has its advantages in construction and repair requirements and the choice is down to your personal preference.*

▶ *ARTF means that the majority of the construction and covering has been completed by the manufacturer, and all you have to do is final assembly of the major parts: perhaps joining the wings and fitting the tail plane. You will still have to install the R/C equipment and the engine, if that has not been included. ARTF models are a very fast and successful method of getting into the air, with most of the work done for you by the manufacturer, but consequently they are the most expensive way to do it. The range of models available is huge, from simple trainers to sophisticated scale aerobatic types. If you buy ARTF, look for the availability of spare parts, sometimes the construction methods do not lend themselves to home repair and you may find yourself needing to buy a new wing or other part.*

▶ *Buying a used model is probably the quickest and cheapest way of getting started, but as for the purchase of any second-hand item, there are pitfalls. Trainers, by their very nature, lead a hard life and any prospective purchase will need to be inspected very carefully. The best course of action is to ask a trusted and experienced club-mate to examine the model for you. You can often pick up a good deal for a model and engine combination, and sometimes even the radio equipment if the seller is upgrading to a more sophisticated set. The advantage to this is that all installation problems will have been dealt with, and the model should be flight proven and trimmed. You need to look out for repairs - if these have been done properly then there should be no problem, but repairs are an indication of a crash and there could be other, undiscovered problems besides the repaired ones.*

## An introduction to R/C - Glide

*Many people prefer the quiet and cleanliness of gliders to power, and there is a huge range of models suitable for use as trainers. By their very nature most gliders are stable and slow flying and a model suitable for learning can be used for many years afterwards for general flying.*

*Most of the FAQ material, radio and model choice for example, applies equally to powered and unpowered models, but of course the absence of a power plant means there are some fundamental differences. Glider trainers will usually have rudder and elevator control, although flat field models may also include air brakes or spoilers, and more advanced models may have a range of lift altering devices.*

*The same criteria of lightness and stability apply to gliders, flat field types particularly will want to be lightly loaded, although models destined for flying from the slopes may be built with a slightly higher wing loading to cope with the higher wind speeds usually encountered. They are also usually smaller than thermal models and built more ruggedly, as few slopes have a flat landing area so the models need to be capable of withstanding arrivals onto rough ground.*

*Gliders can be split into 2 main categories, **Flat Field** and **Slope** soarers. The two are not mutually exclusive, any type of glider can be used on either slope or flat, but of course with varying degrees of success. Within these two categories are a huge range of specialist subdivisions: just as for power there are sport, scale, aerobatic, pylon racing and duration types.*

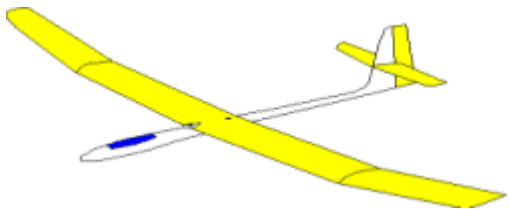

**Flat Field.**

*Flat field models can be flown from the same type of site as powered models, and in many clubs the two types are operated side by side. Flat field models rely on thermals to stay airborne. Thermals are columns of rising air generated by heat in the ground. On a good sunny day a thermal may rise many thousands of feet into the air, and full-size glider pilots take full advantage of them to climb to tremendous altitudes, allowing flights of hundreds of miles to be undertaken. R/C gliders use thermals in the same way, although they are limited in altitude by the eyesight of the pilot.*

*Thermal gliders are launched either by an aero-tow or some sort of ground-based line.*

.....

## Aerotow

*This is the same method as used by full-size gliders. A powered model, the tug, is fitted with a length of line which is attached to the nose area of the glider. The tug pilot then takes-off, towing the glider up to the required altitude. The line is attached at both tug and glider end with a radio controlled release so that the glider pilot can cast off when ready and then search for thermals. The tug pilot also has a release so that the glider can be dropped in case of problems.*

---



## Around launches

*These use either a bungee, winch or hand-tow.*

### *A Bungee*

---

*Is a length of some elastic material, extended by a longer length of non-elastic line. The end of the elastic length is fastened to a stake in the ground, and the other end has a ring which is slipped over a hook on the bottom of the glider fuselage. The glider is then pulled backwards, stretching the bungee, and when a suitable tension is achieved the glider is released and the contraction of the bungee pulls the model into the air.*

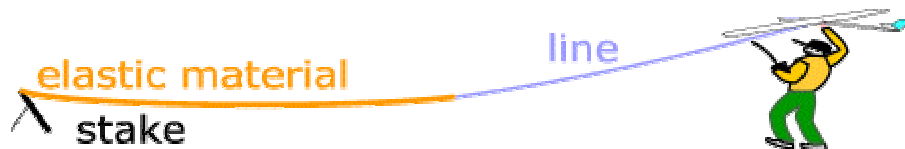

### *A winch*

---

*is an electrically powered spool wound with line. One end is attached to a hook under the model fuselage, the*

*other is fed around a pulley and onto the spool. When the motor is activated the line is wound rapidly onto the spool, winching the glider into the air. The motor is usually activated by the pilot with a foot switch, and the motor is pulsed on and off to adjust the line tension and hence the model speed.*

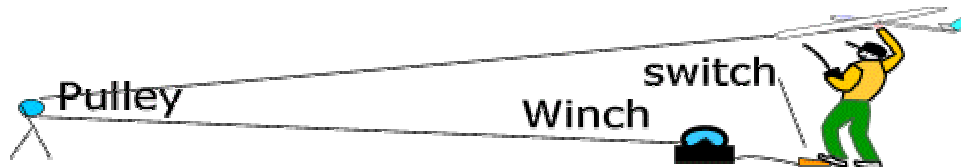

### *A Hand tow*

---

*Is the simplest: a length of line attached to the glider at one end, and held at the other by someone capable of running fast! This tows the glider into the air. Sometimes the line is wrapped around a pulley to get a mechanical advantage; sometimes more than one person is used to pull the towline.*

## Slope



*Slope Soarers are designed to be flown off hills, where the lift needed to keep the model aloft is generated by the wind blowing up the slope of the hill. They are usually launched by standing at the top of the slope, facing into the wind, and throwing the model forward into the lift. The model is then tacked backwards and forwards across the slope, gaining height from the lift generated by the flow of wind. On a good slope this lift can extend many hundreds of feet into the air, and models may be climbed until almost out of sight.*

*Slope flyers are not restricted to slope generated lift: on hot days there may be thermals which can be used in the same way as by the flat field flyers, and in some locations, where there are other hills upwind, there may be wave lift to make use of.*

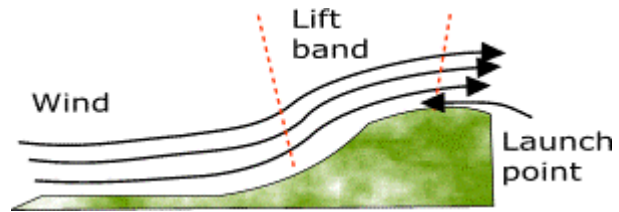

*Once you are airborne, you can keep flying as long as the lift, and your radio battery, lasts. This makes slope soaring an excellent way to build up flying hours, there being no need to keep landing to refuel or recharge. The basic flying skills, and the manoeuvres needed to fly and land safely are similar enough to power flying that they are easily transferred. The drawbacks are the lack of landing practice - you can't do touch-and-goes with a slope soarer - and the reliance on the wind for lift. If the wind drops, you have to stop flying. However, for many people the lack of an engine, and its attendant noise and oily residues, make slope soaring the most attractive type of modelling.*

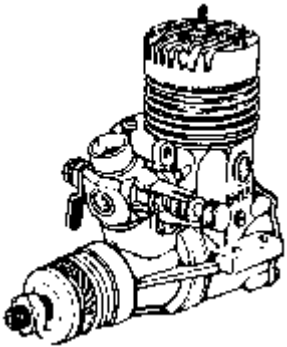

## *Two stroke*

### Types of Engines

*The traditional version is based on compression-ignition technology, colloquially referred to as 'two stroke'. This covers both 'glow' and 'diesel' engines.*

*The vast majority of model engines are glow engines - so called because to ensure ignition each cycle, they are fitted with a glow-plug in the cylinder head. This has the appearance of a spark plug, but has a small coil fitted in its centre instead of an electrode. To start the engine a low voltage power source is applied to the plug to make the coil glow red hot, this then ignites the fuel.*

*Once the engine is running the residual heat from each explosion cycle, together with a chemical reaction initiated by the catalytic platinum plug element, ensures that the glow plug element remains hot enough to ignite the fuel on the next cycle and the power supply*

to the plug can be removed. The fuel is primarily methanol, with up to 25% oil for lubrication, and usually a smaller percentage (around 5% is typical, but it can be much higher for specialist applications) of nitro methane, a chemical additive which improves the combustion efficiency of the methanol.

The alternative type of 2-stroke is the diesel engine. This is outwardly similar, but instead of a glow plug, there is an adjuster, which moves a 'contra-piston' in the cylinder head, altering the compression ratio of the engine. The fuel used is a mixture of ether, paraffin and oil: the ether component has a low flash point, and when compressed by the engine, the temperature rise caused by the compression is sufficient to cause ignition. The adjuster is used to vary the compression ratio until smooth running is achieved. This type of engine, because of the adjustable available can be set up to turn a bigger prop than a similar capacity glow engine.

---

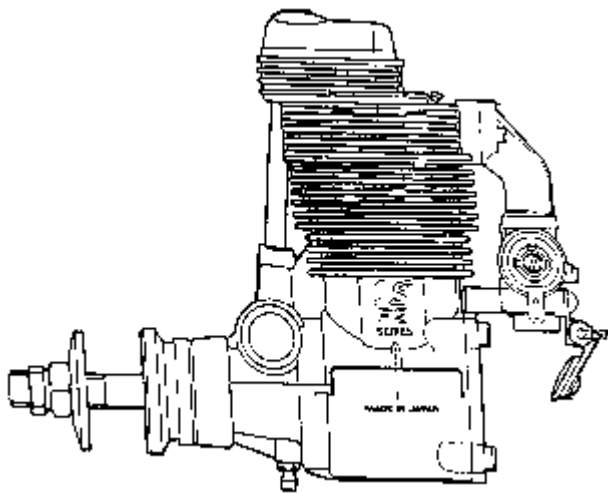

## Four Stroke

The other type of engine that is gaining in popularity is the four stroke. These engines are more complex to manufacture, hence more expensive, and have always had a lower specific power output, but because they tend to have a quieter exhaust note, and to most ears a more realistic sound, they are very popular in scale models. The disparity in power output is not as pronounced as it was and they are now a good choice for any type of model.

They work in the same way as the familiar car engine, complete with overhead valves, but tend to be pushrod operated not overhead cam. There are also variations with side valves, rotary valves, and a recent development is a rotary sleeve valve. The illustration shows a typical engine: the pushrods are at the front, operated by a cam driven by the crankshaft, and the carburettor is behind the cylinder. The flap underneath the carb. is a rod operated choke, often needed because the position of the carb. makes it difficult to choke the engine with the traditional finger! The exhaust exits from the cylinder head on the other side, and is sometimes just a plain header pipe, but more often incorporates a small silencer.

The engines illustrated are single cylinder, but there are multi cylinder versions of both types of engine. You may find in-line, horizontally opposed or radial versions available. These can be particularly effective when used in scale models.

---

## *Jet Engines*

*Recent developments in engineering and materials technology has now made it possible to create a true jet engine in a size suitable for model use. They operate at extremely high revolutions and temperatures, using liquid or gaseous fuels such as propane. Currently they are definitely a specialist engine and are very highly priced, with specialist installation and operating skills required. No doubt as development continues they will become both cheaper and easier to operate, making them suitable for general use.*

*The huge advantage is the possibility of creating a true scale model of a Jet aircraft, complete with an authentic sound, and this attraction means that the number of model jet engines available and in use is increasing rapidly.*

---

## *Electric*

*Finally you might be considering an electric powered aircraft. These motors have many advantages over the traditional powerplant, being quiet, clean, and compact. Modern materials mean that they are not disadvantaged in power to weight ratio compared to liquid fuelled motors, and most model designs can easily be converted to an electric powerplant. With the ever-increasing sensitivity to noise of many flying sites, electric powered models provide a way of enabling flying to take place without disturbing the neighbours.*

*One other advantage is the ability to stop and start electric motors at will, something which is much more difficult to achieve with glow motors. This ability makes them ideal as launching powerplants for gliders, replacing winch or bungee as a means of getting to altitude. Once at the required height, the motor can be stopped and the glider flown using thermals while still retaining the ability to climb back to altitude if lift cannot be found.*